

**TOWN OF PORTLAND  
SEWER DIVISION**

**BUILDING SEWER CONNECTION – GENERAL INFORMATION**

**FEES**

Permit & Inspection Fee	\$75.00
Sewer User Fees	See attached sewer use charges

**General Requirements**

1. No person shall make any connection to the sewer system unless a valid building sewer connection permit is issued by the Town. Prior to issuance of any connection permit, the permit and inspection fee of \$75.00 must be paid.
2. Application for a building sewer connection permit must be made by the owner of the building which is to be connected with the public sewer, on the attached application form. A separate permit is required for each building to be connected.
3. Connection to the public sewer is mandatory for new buildings and new building additions and for buildings with failing septic systems or where partial septic repairs were allowed by the Sanitarian, pending sewer installation.
4. The Town's Sewer Ordinance, adopted March 9, 1982 and subsequent regulations and details will apply to the workmanship and materials associated with the connection and use of the sewers.
5. Building sewer connection permits will only be issued to:
  - A licensed contractor holding a valid State of Connecticut license to perform the unsupervised installation of sewer mains, services and appurtenances: or
  - A person owning and residing in a single-family house and installing his/her building sewer pipe within the confines of his/her property.
6. The owner/contractor must consult with the Public Works Department prior to commencing any work on the building sewer connection to review scheduling, as-built location of the existing lateral stub to the property and the Town's sewer ordinance requirements.
7. The owner/contractor shall notify the Connecticut "Call Before You Dig" clearinghouse at (800) 922-4455 in accordance with the requirements of Section 16-345-1 through 16-345-7, inclusive of the Regulations of Connecticut State Agencies, Department of Public Utility Control and shall provide the Town with the CBYD location request number.

8. The Owner/Contractor will be required to post with the Town, a Certificate for Public Liability Insurance (\$100,000 Ea. Person, \$1,000,000 Ea. Accident, a \$50,000 Property Damage), a Performance and Guaranty Bond (\$5,000), and a copy of their current Contractor's License Certificate, where applicable.
9. No trench containing a sewer pipe or other appurtenance can be backfilled until the Town Inspector or his authorized agent has completed an inspection and found the work to conform to the requirements of the Town in all respects and to be satisfactory as to the quality of workmanship and materials. The Contractor/Owner must notify the Town Inspector (342-6733) twenty-four (24) hours before starting any work authorized under the permit, and for subsequent inspections.
10. Any person who is in violation of any sections of the Town's Sewer Ordinance and other applicable regulations, or fails to give adequate notice to the Town Inspector for an inspection of the work, may be halted and/or required to uncover the work for inspection and approval.
11. Permits may be revoked and annulled by the Town for any violation of the Town's Sewer Ordinance, or suspended for a reasonable time, to permit the Town to make an investigation to determine if there has been a violation of the regulations.
12. Permits shall be valid for a period of three hundred sixty-five (365) days, except in the event the property changes ownership before the work is completed or if another Contractor is chosen to perform or complete the work, the original permit becomes void and a new permit shall be obtained by the new parties in interest.
13. All connections requiring easements and/or other agreements must have such easements and/or agreements approved executed and recorded on the Land Record prior to issuance of a permit for connection to the sanitary sewer.
14. All excavations for building sewer installation shall be adequately guarded with barricades and lights so as to protect the public from hazards.
15. No roof downspouts, foundation drains, sump pumps or any sources of surface runoff or groundwater can be connected to the building sewer or public sewer.
16. Any change in direction of the building sewer exceeding a 45 degree angle must have a cleanout.
17. All septic tanks must be abandoned by being pumped out, removed or crushed and filled. The Town Inspector must be contacted to confirm that the septic tank has been properly abandoned.
18. Any relocation/replacement of sewer piping inside the building, requires a plumbing permit and inspection from the Building Official (342-6727).

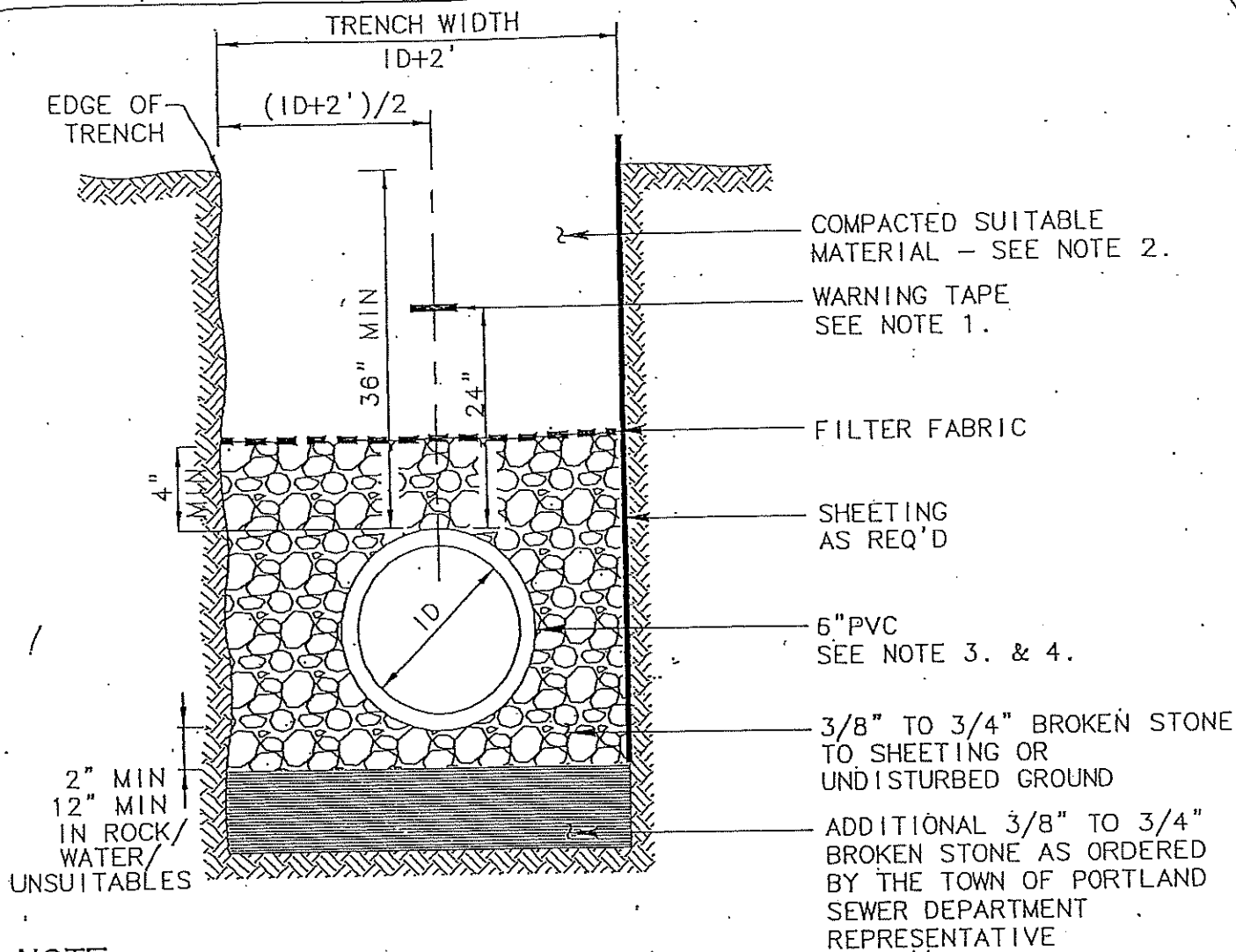

**NOTE:**

1. WARNING TAPE SHALL BE OF DURABLE IMPERVIOUS MATERIAL, DESIGNED TO WITHSTAND EXTENDED UNDERGROUND EXPOSURE WITHOUT MATERIAL DETERIORATION OR FADING OF COLOR. WARNING TAPE SHALL BE DETECTABLE TO A DEPTH OF AT LEAST THREE FEET WITH A COMMERCIAL RADIO-TYPE METAL LOCATOR. THE WARNING TAPE SHALL BE COLOR GREEN.
2. COMPACT BACKFILL TO AT LEAST 95% OF MAXIMUM DENSITY PER ASTM D-1557. BACKFILL WITHIN 18" OF TOP OF PIPE TO BE FREE OF STONES/ROCKS > 4" IN DIAMETER.
3. MIN SLOPE OF HOUSE CONNECTION SHALL BE 1/4"/FT.
4. POLYVINYL CHLORIDE (PVC) SEWER PIPE SHALL CONFORM TO THE REQUIREMENTS OF ASTM D3034 AND SHALL BE SDR35.

**CONNECTION LATERAL TRENCH SECTION**

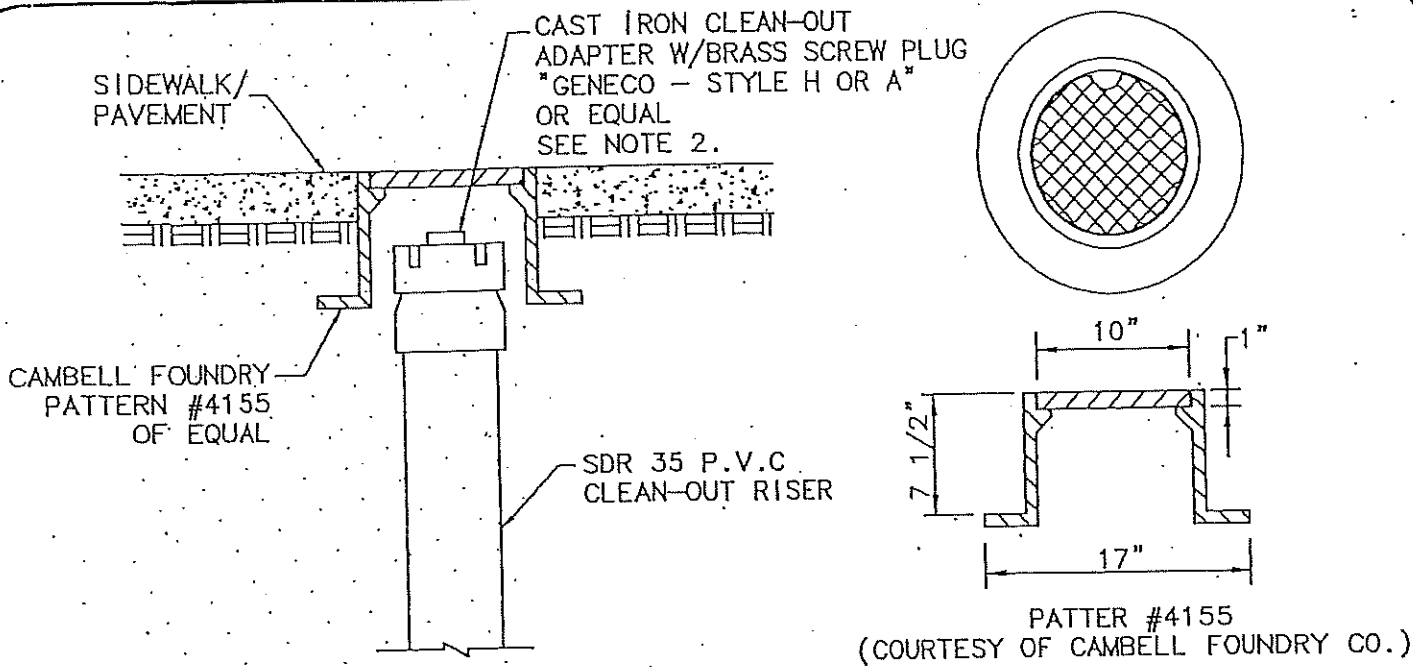

**SIDEWALK/PAVEMENT  
SEWER BOX DETAIL**

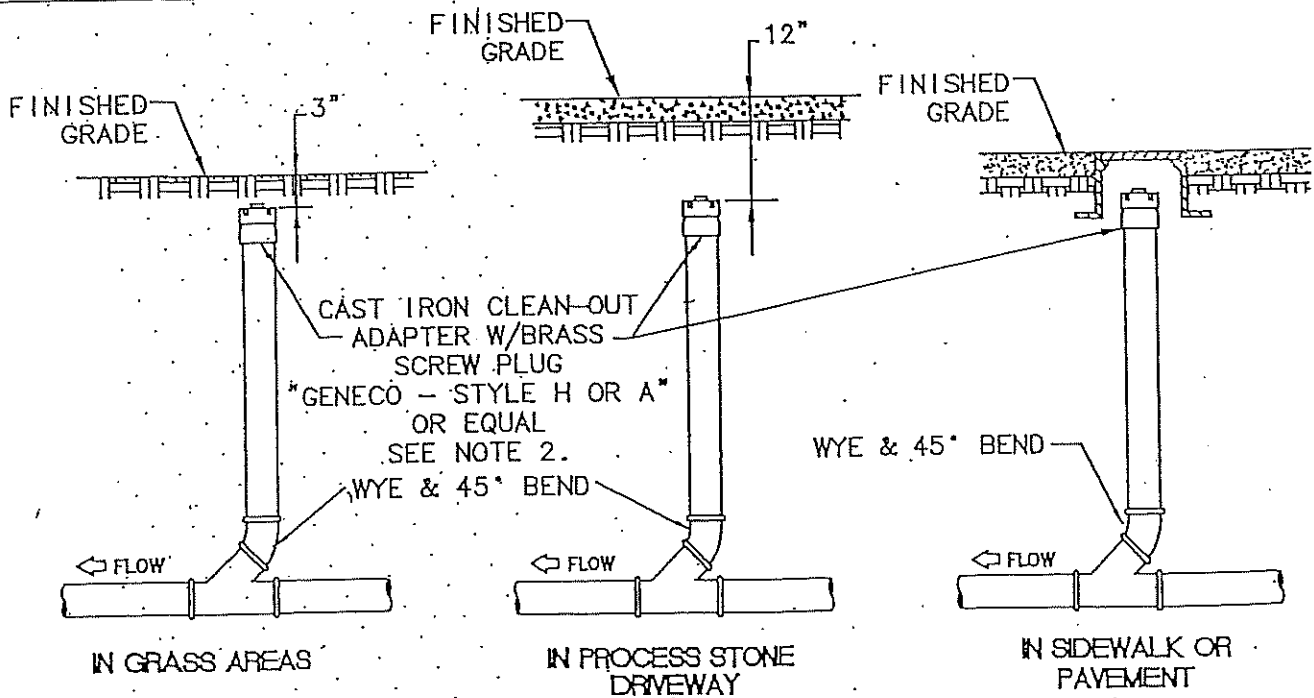

**NOTE:**

1. CLEANOUT PIPES SHALL BE OF THE SAME DIAMETERS THE BUILDING SEWER.
2. ALTERNATE, CONTRACTOR MAY SUBSTITUTE PVC SDR 35 CLEAN OUT ADAPTER AND SCREW PLUG.

**CLEANOUT DETAILS  
N.T.S.**

**TOWN OF PORTLAND – SEWER DIVISION  
APPLICATION FOR PERMIT TO CONNECT TO THE SANITARY SEWER**

Permit No. \_\_\_\_\_

Building Address \_\_\_\_\_ Number of Units \_\_\_\_\_

Tax Map & Lot No. \_\_\_\_\_

Property Owner \_\_\_\_\_

The undersigned property owner/agent hereby requests permission for a building sewer connection and agrees to conform to all Ordinances, Rules and Regulations set forth by the Town of Portland, Sewer Division, pertaining to the connection to and use of the sanitary sewer. The undersigned property owner/agent also agrees to maintain and protect and if damaged or disturbed to repair all property and utilities.

The undersigned property owner authorizes \_\_\_\_\_ to perform all  
(Contractor)  
work associated with the building sewer connection.

\_\_\_\_\_  
Signature of Property Owner

\_\_\_\_\_  
Date

\_\_\_\_\_  
Signature of Contractor

\_\_\_\_\_  
Date

**TOWN OF PORTLAND – SEWER DIVISION  
BUILDING CONNECTION PERMIT**

Building Address - \_\_\_\_\_ Permit No. \_\_\_\_\_

Owners Name - \_\_\_\_\_ Phone No. \_\_\_\_\_

Owners Address - \_\_\_\_\_

Contractor's Name - \_\_\_\_\_ Phone No. \_\_\_\_\_

Contractor's Address - \_\_\_\_\_

Contractor's License No - \_\_\_\_\_ Date Bond Posted \_\_\_\_\_

Date Fee Paid/Permit Issued - \_\_\_\_\_ By \_\_\_\_\_  
(Initials)

=====

Building  
Served

Street - ..... Line  
Edge ..... Road

=====

I certify that the work was performed in accordance with all requirements of the Sewer Ordinance.

\_\_\_\_\_  
Contractor's Signature

\_\_\_\_\_  
Date

Connection Inspected and Approved By: \_\_\_\_\_  
Inspector

\_\_\_\_\_  
Date

**THE FOLLOWING DISCLOSURE NOTICE CAN BE USED WHEN  
COLLECTING ETHNICITY/RACIAL/SEX DATA FOR  
MONITORING PURPOSES**

The following disclosure should appear in the monitoring section of the application form, or if using a separate document for monitoring information, the disclosure should appear immediately above the request for monitoring information

*The following information is requested by the Federal Government in order to monitor our compliance with various Federal civil rights laws. You are not required to furnish this information, but are encouraged to do so. The law requires that we may not discriminate based upon this information, nor whether you choose to furnish it. However, if you choose not to furnish it, under Federal regulations, we are required to note the race and sex on the basis of visual observation or surname. This information will not be used in evaluating your application or to discriminate against you in any way.*

*( ) I do not wish to furnish this information*

*Ethnicity ( ) Hispanic or Latino  
( ) Not Hispanic or Latino*

*Race/  
National Origin ( ) American Indian or Alaskan Native  
( ) Asian  
( ) Black or African American  
( ) Native Hawaiian or Pacific Islander  
( ) White*

*Sex ( ) Male  
( ) Female*

Handbooks, pamphlets, and other materials distributed to the public, describing the recipient's program(s); or facilities and the requirements for participated will contain the following statement:

**"In accordance with Federal Law and U.S. Department of Agriculture policy, this institution is prohibited from discriminating on the basis of race, color, national origin, sex, age or disability. (Not all prohibited bases apply to all programs).**

**To file a complaint of discrimination, write USDA, Director, Office of Civil Rights, Room 326-W, Whiten Building, 1400 Independence Avenue, SW, Washington, DC 20250-9410 or call (202 720-5964 (voice and TDD). USDA is an equal opportunity provider and employer."**

If the material is too small to permit the full statement to be included, the material will at a minimum include the statement, in print size no smaller than the text, that "This Institution is an Equal Opportunity Provider"